

Advanced Use of Coal-fired Power Generation And International Cooperation in the Electric Power Industry

September 7 (Tue), 2010

**Zengo Aizawa
The Tokyo Electric Power
Company, Incorporated**



東京電力

<Contents>

I. Current Situation and Prospects of the Use of Coal-fired Power in the Electric Power Industry

II. Approaches to Advanced Use of Coal-fired Power

III. International Cooperation through Coal-fired Power Technologies

I. Current Situation and Prospects of the Use of Coal-fired Power in the Electric Power Industry

II. Approaches to Advanced Use of Coal-fired Power

III. International Cooperation through Coal-fired Power Technologies

Distribution and Reserves of Energy Resources

About 60% of petroleum is concentrated in the Middle East, whereas coal is distributed widely around the world, mostly in politically-stable countries. The reserves-to-production ratio is also higher than that of other energy resources.

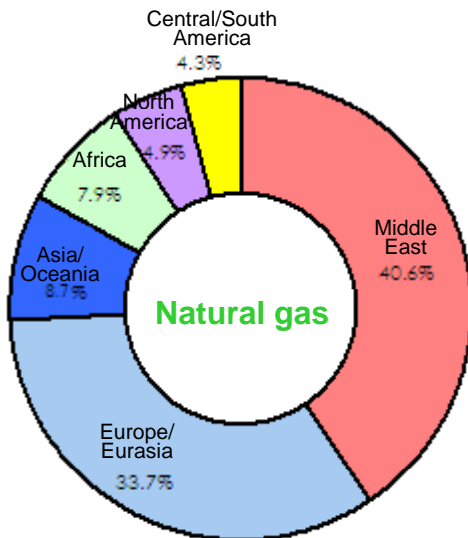
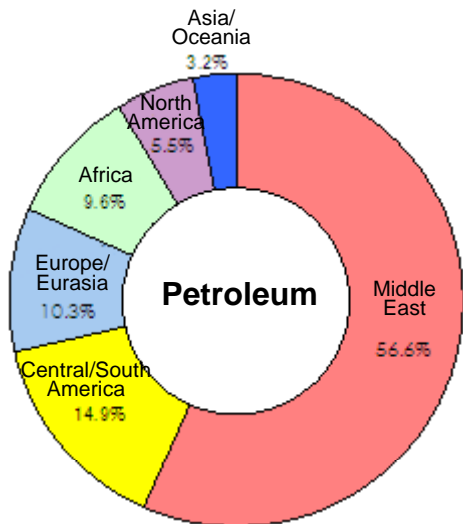

Breakdown of Reserves of Each Energy Resource

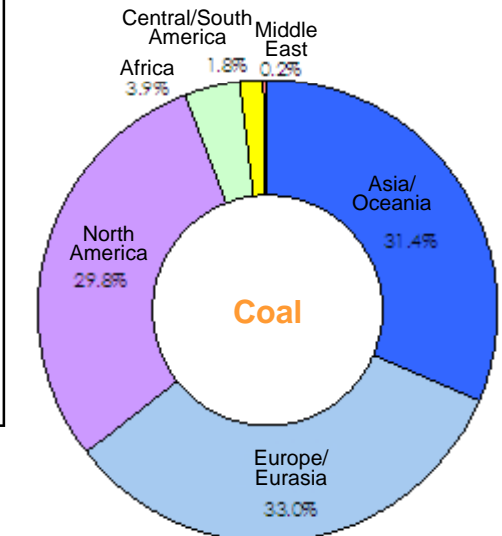
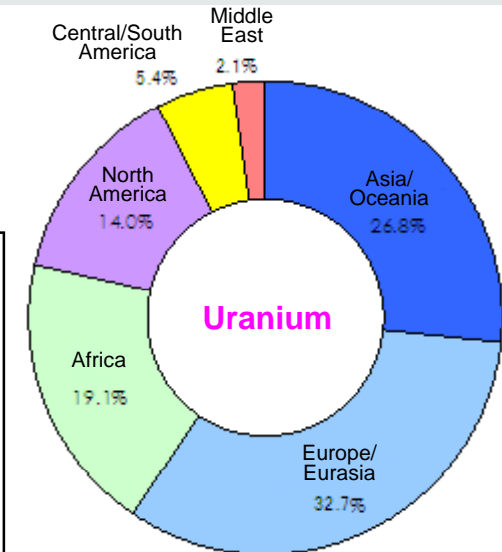
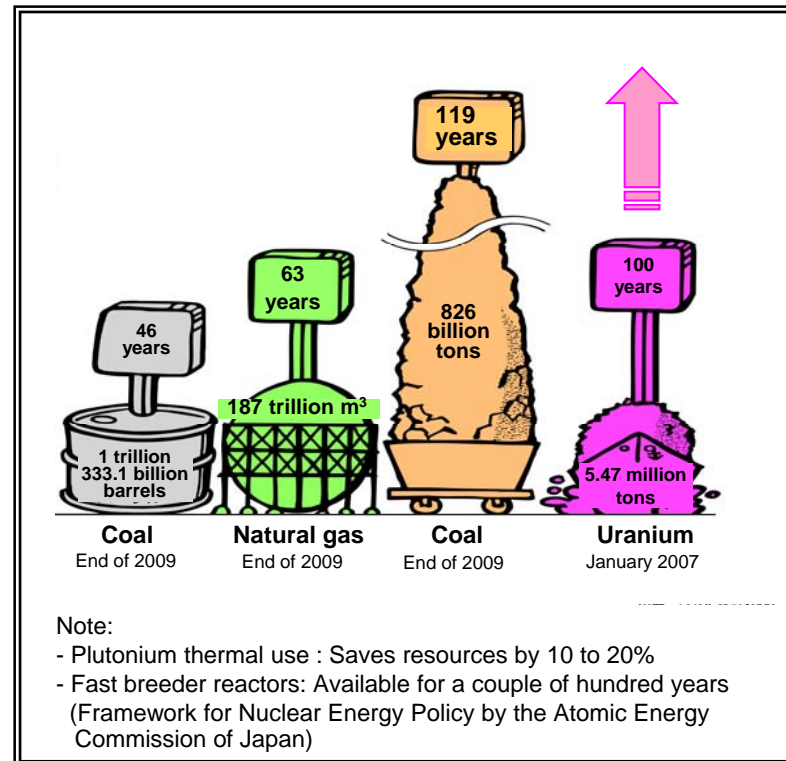

Source: BP Statistics 2010
IEA URANIUM 2007

Comparison of Economic Efficiency of Each Fuel

- Coal, LNG, and petroleum are advantageous in that order in terms of economic efficiency.
- Fuel coal prices are relatively stable, therefore coal becomes more advantageous than petroleum and LNG when oil prices are soaring.

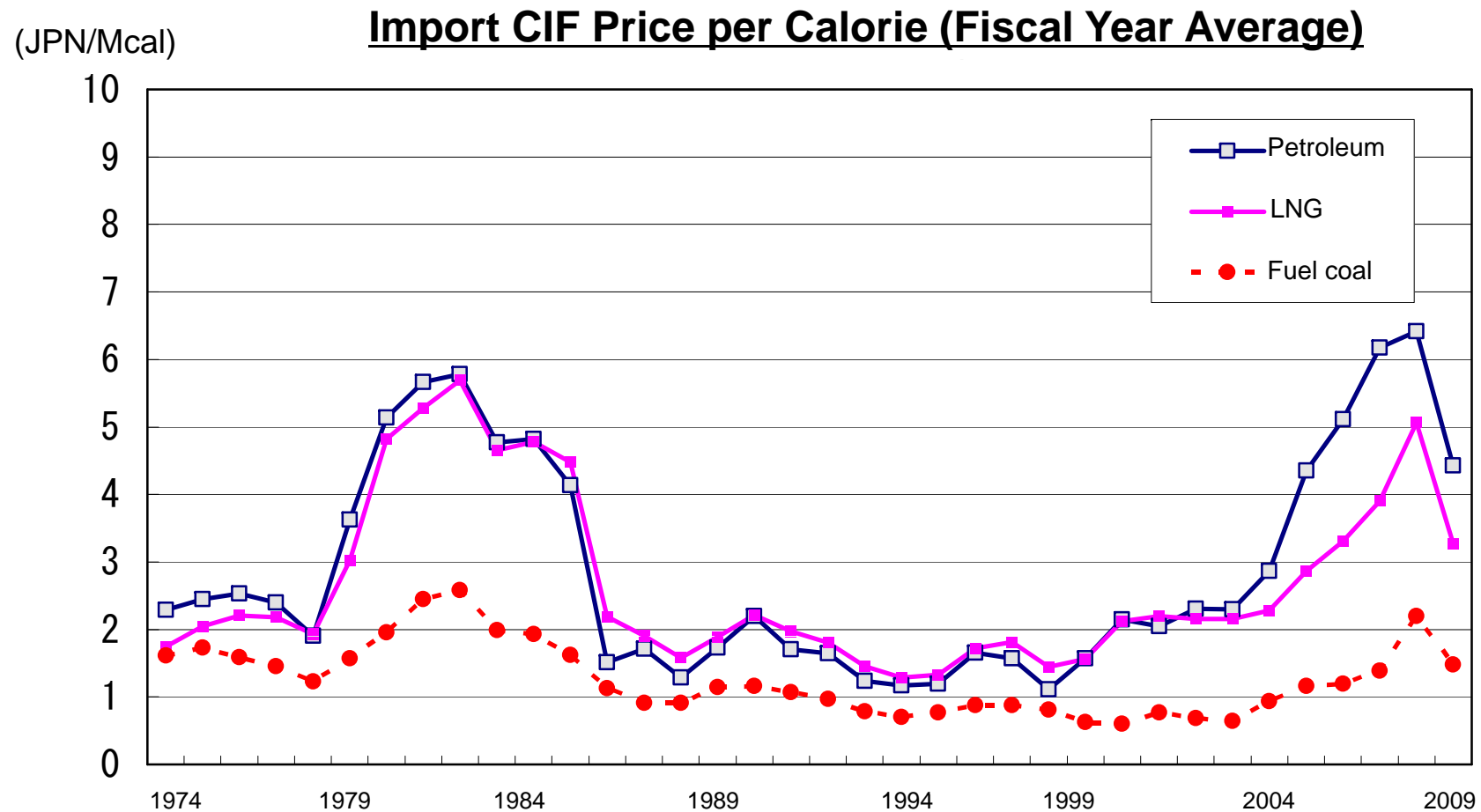

Source: 2010 Handbook of Energy & Economic Statistics in JAPAN, Sekiyu Shiryo Geppo (Monthly report on petroleum data)

Lifecycle CO₂ Emission Factor for Each Power Generation Method

■ Coal-fired power plants generate the highest CO₂ emissions per kWh.

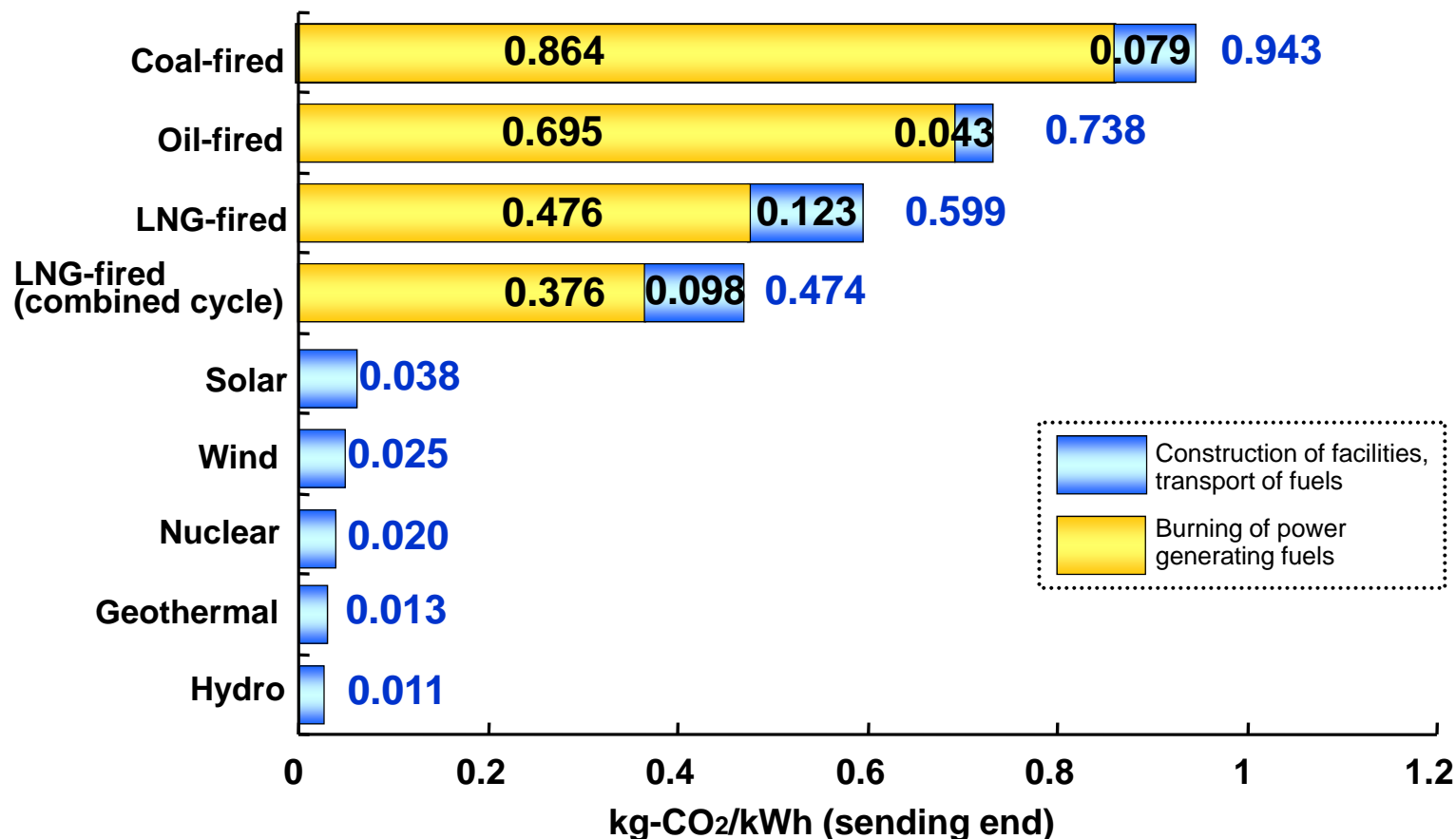

Note: CO₂ emissions were calculated covering all energies consumed from mining of raw materials to construction of various facilities, transport of fuels, purification, operation & maintenance, etc. besides burning of power generating fuels. Currently projected recycling of nuclear fuels (including domestic reprocessing of used fuels, plutonium thermal use for which one recycling is assumed, and high-level radioactive waste disposal) was assumed for nuclear power generation.

Source: Central Research Institute of Electric Power Industry

Transition of Composition of Electric Energy Generated in Japan

- After the Oil Shocks power generation in Japan has made the transition from the power generation depending on petroleum to the Best Mix (optimum energy mix) over long periods of time. **Coal-fired power has also been promoted together with nuclear power and natural gas.**
- The electric power companies will continue to **promote the Best Mix of power sources** in which each energy resource is combined keeping its own balance of stability.

<Transition of composition ratio of electric energy generated in Japan (by energy)>

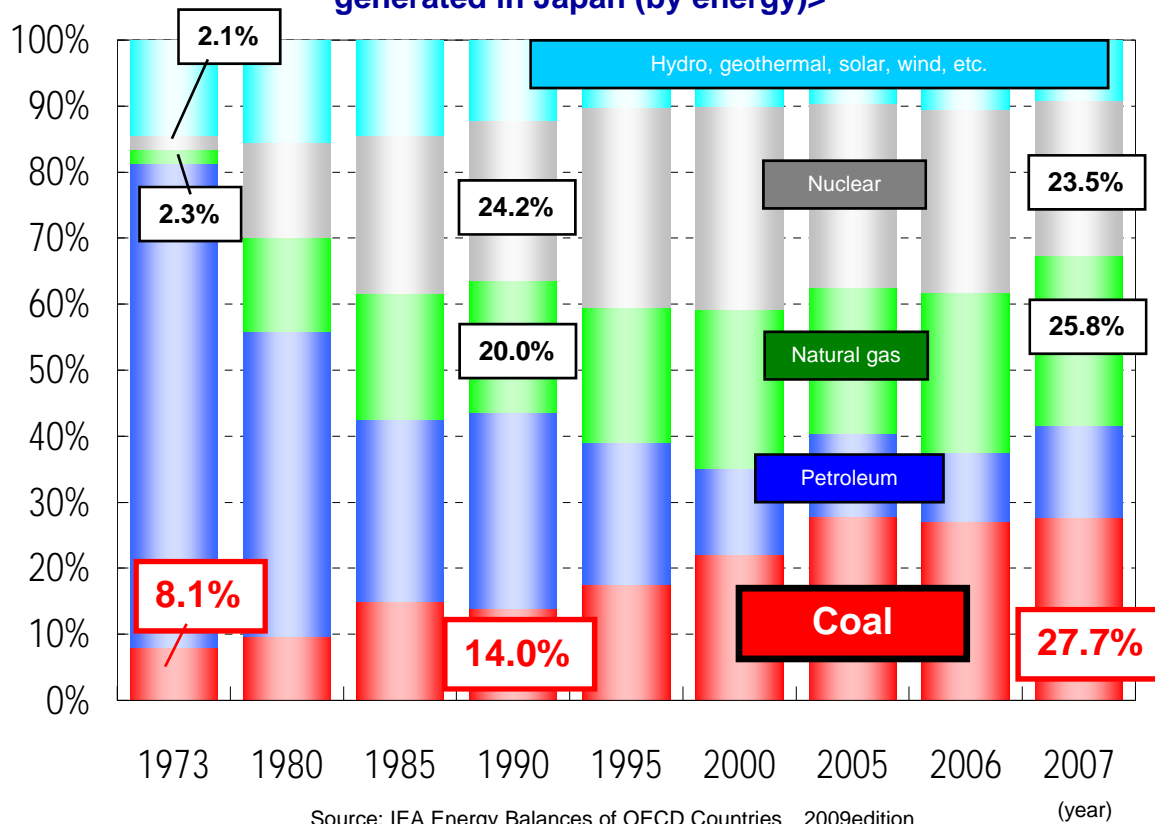

<Forecast of electric energy generated in Japan>

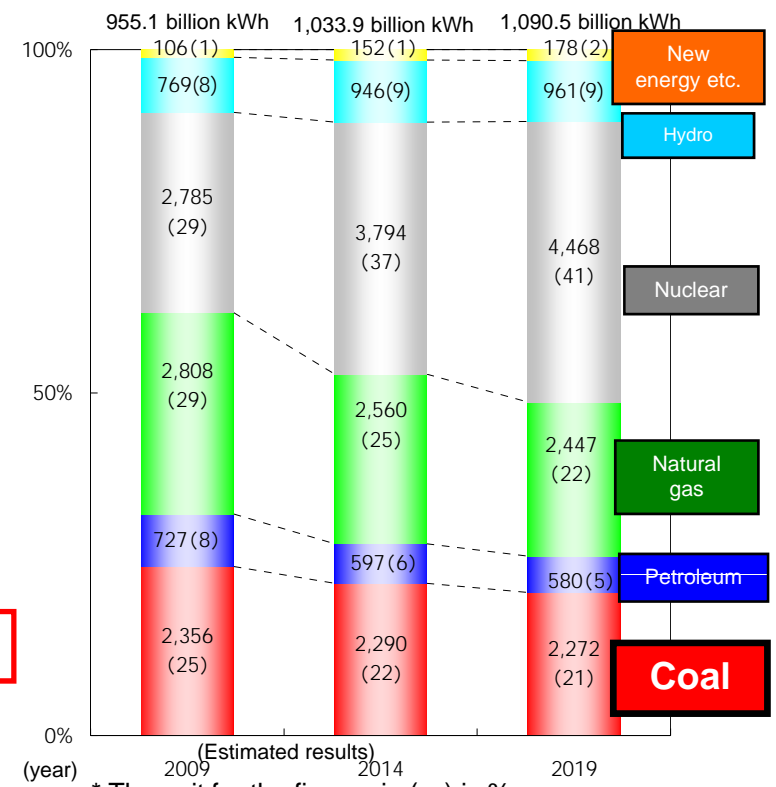

International Comparison of Composition of Electric Energy Generated (2007) I II III

Coal-fired power is one of the major power sources in various countries such as the US, the UK, Germany, China, and India.

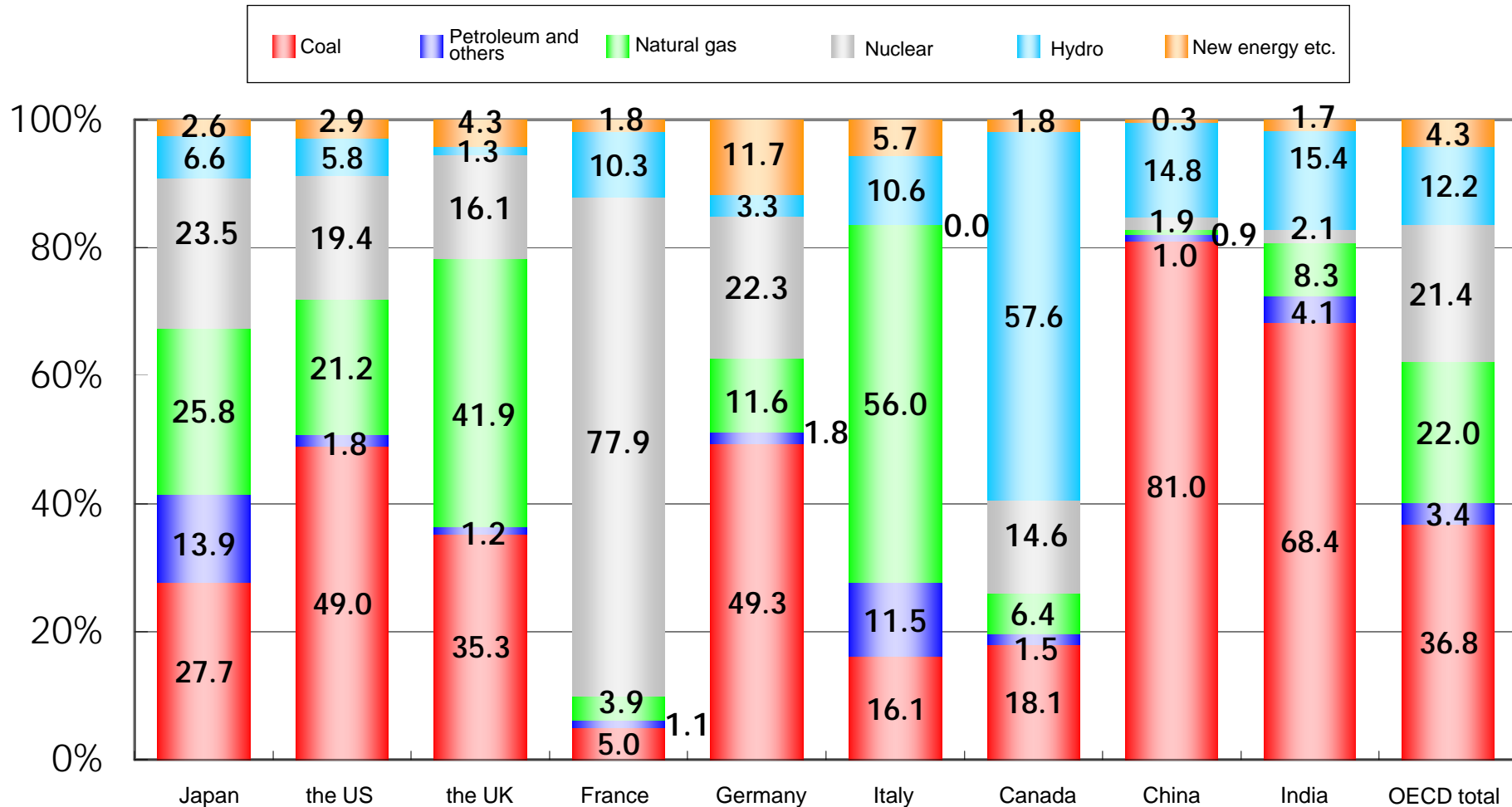

Source: IEA Energy Balances of OECD/Non-OECD Countries 2009edition

Prospects of Utilization of Coal-fired Power in Each Country by 2030



It is estimated that coal-fired power will be continued to be used as a major power source in the future in the US, OECD European countries, China, and India. In particular, the increase in China and India is remarkable.

<Transition of the composition ratio of electric energy generated in each country>

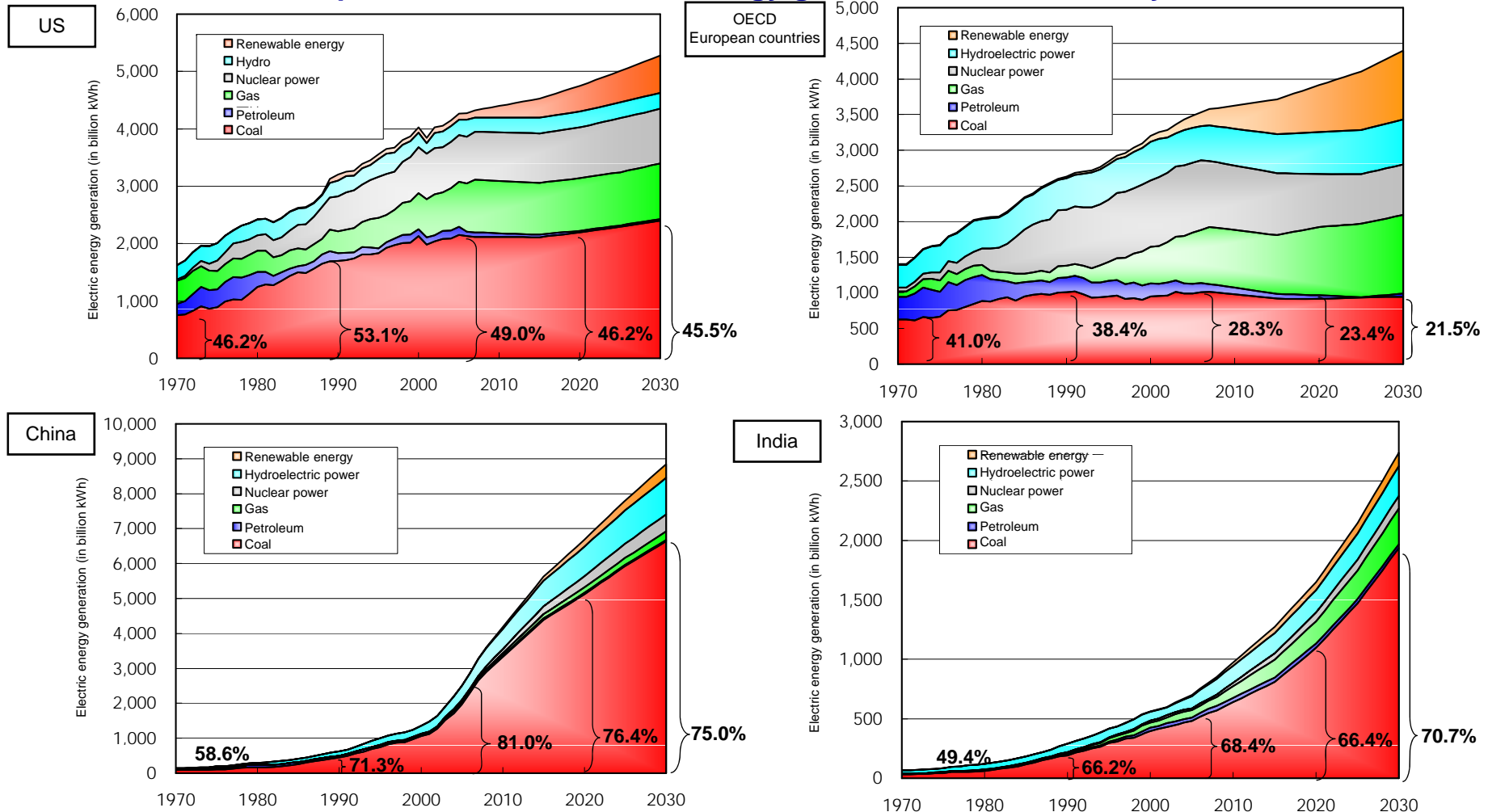

Source: IEA Energy Balances of OECD Countries 2009 edition, World Energy Outlook 2009



I. Current Situation and Prospects of the Use of
Coal-fired Power in the Electric Power Industry

II. Approaches to Advanced Use of Coal-fired Power

III. International Cooperation through Coal-fired
Power Technologies

History of Improvements in Efficiency of Coal-fired Power Plants in Japan I II III

Technology development has been promoted for effective use of coal and environmental measures responding to the social climates of the time.

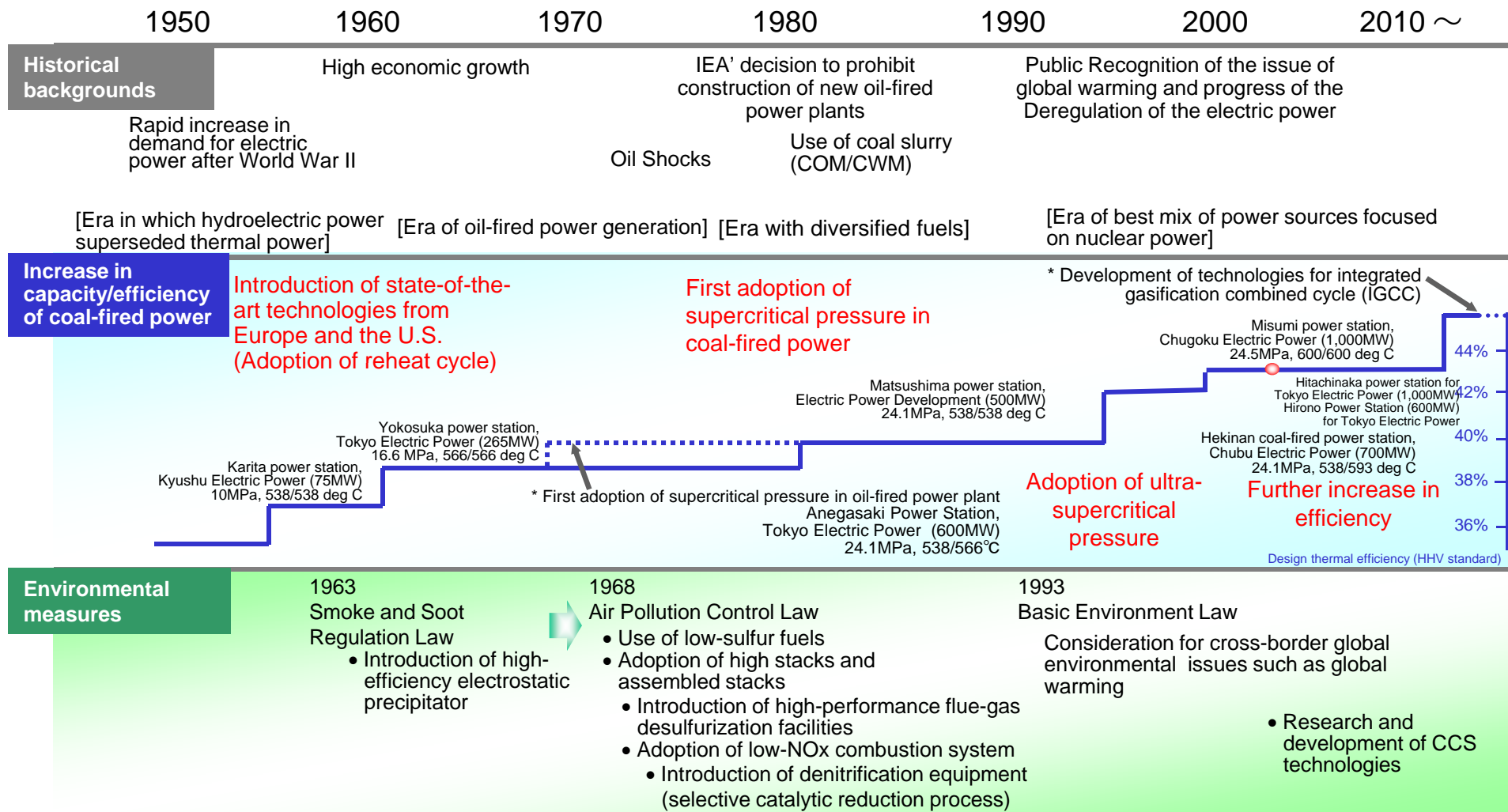

Source: The Thermal and Nuclear Power, October 2006

International Contributions of Japan with Its Coal-fired Power Technology

- The thermal efficiency of coal-fired power plants in Japan is **the world's best standards**.
- The BAT (Best Available Technology) at construction of new coal-fired power plants and improvement of operation and maintenance would allow reduction of **1.87 billion-ton of CO₂** in 2030 in the entire world.
- It is necessary to possess and keep operating the world's highest level of coal-fired power technology, so that Japan makes international contributions in the future for China and India, which mainly utilize coal-fired power plants.

<Comparison of thermal efficiency of coal-fired power plant >

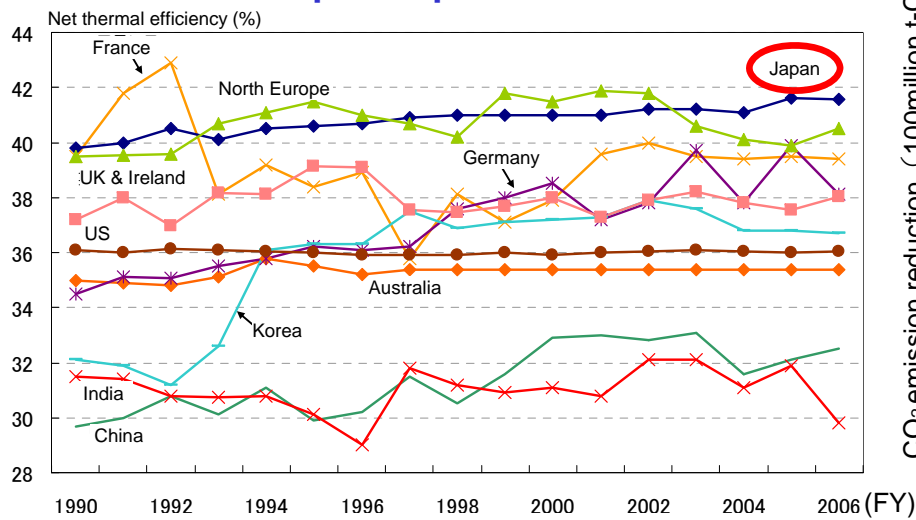

[Source] "INTERNATIONAL COMPARISON OF FOSSIL POWER EFFICIENCY AND CO₂ INTENSITY" ECOFYS, 2009

<Comparison of CO₂ reduction (2030)>

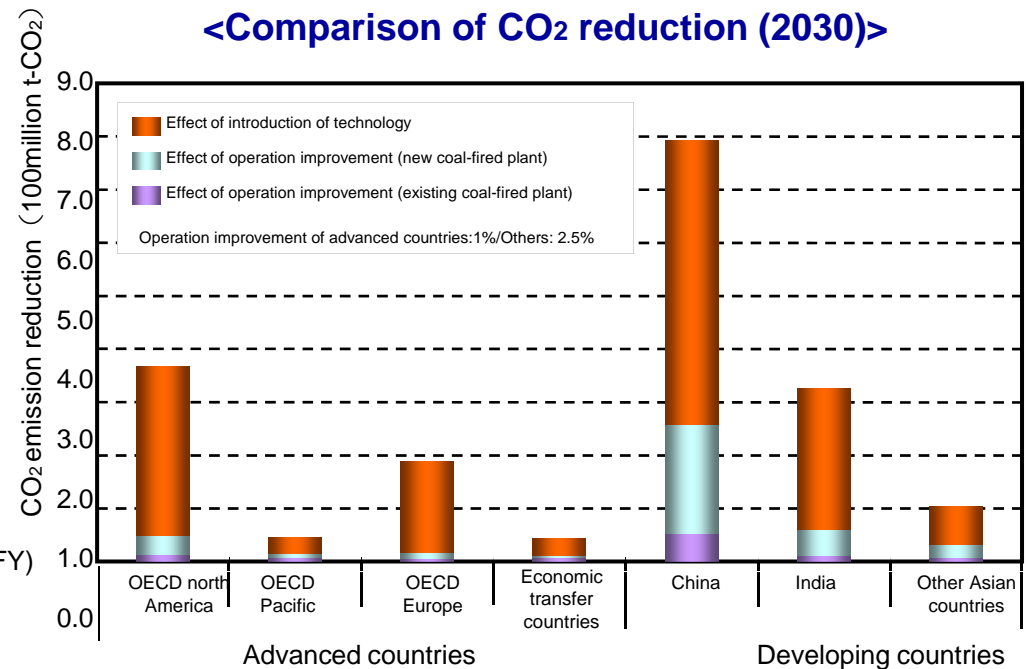

[Source] Estimation by FEPC based on the data of IEA IEA/World Energy Outlook 2006, IEA/Energy Balance 2005, and Platts 2007

- Basic Energy Plan (cabinet decision at June 18) gives coals the status of excellent energy source in terms of cost and the security of supply, except for relatively higher CO₂ emission, and describes;

- Establishing the coal utilization technology in harmony with global environment and use it appropriately in the future
- Maintaining competitiveness of its world's best coal utilization technology and promote it worldwide.

(1) Advanced utilization of fossil fuel

- Promotion of improvement of efficiency at existing coal-fired power plants, multi-fuel combustion with biomass, and introduction of latest facilities by replacement of degraded coal-fired power facilities
- Controlling CO₂ emission of newly added or replaced coal-fired power plants basically as a same level as IGCC
- Development and demonstration by the state and the people hand in hand, aiming at improvement of efficiency of IGCC, A-USC, and others and early practical application
- Consideration of introducing CCS Ready for future project of new construction and addition of coal-fired power plants

(2) Promotion of international deployment in energy and environmental fields

- Promotion of international deployment with emphasis on high-efficiency technology such as USC and advanced operation and management technology that we specialize in.

Technology Development Road Map Aiming at Improvement of Future Coal-fired Power Utilization



- "Cool Earth Energy Innovative Technology Plan (announced in March 2008) " settled "Energy technology development road map toward 2050."
- Based on Basic Energy Plan, a new innovative energy technology road map will be settled within 2010.

<Energy technology development road map toward 2050 (coal-fired power)>

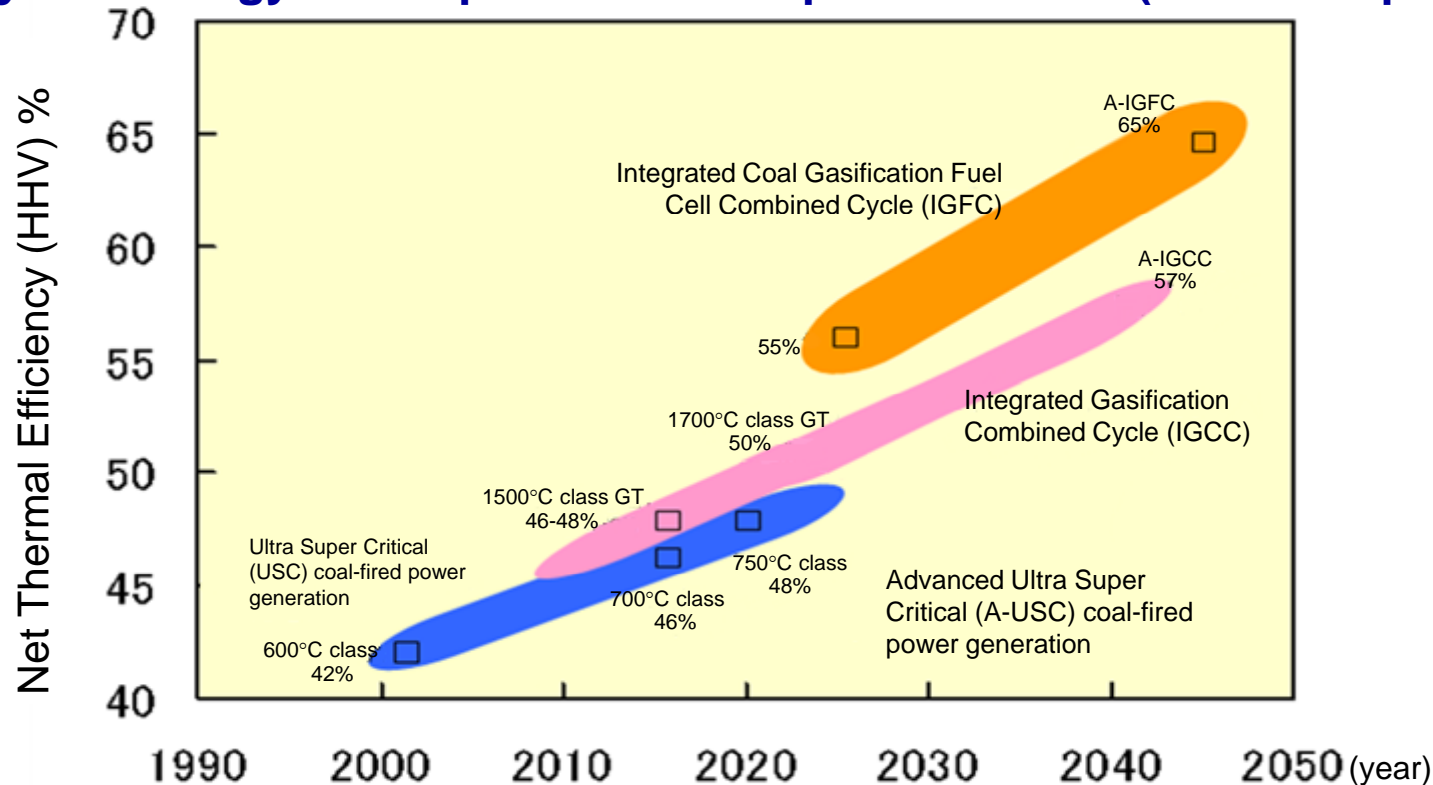

[Source] Created by Agency for Natural Resources and Energy based on "Cool Earth Energy Innovative Technology Plan"

Integrated Gasification Combined Cycle (IGCC)

- IGCC: Technology to create combustible gas by the reaction between coal and air at high temperature and generate the power with combined cycle.
 - Thermal efficiency of IGCC (1,500°C class): 48-50% (HHV), at the level of commercialization
 - Compared with the existing coal-fired power plants, almost 20% of CO₂ emission factor can be reduced (same level as oil fired power plants.)
- Clean Coal Power R&D Co., Ltd. that nine electric power companies and J-Power established is conducting a demonstration test at Nakoso (Iwaki City, Fukushima) with an IGCC demonstration facility.
- In three years after the start of operation, it successfully achieved the 2,000-hour continuous operation test and the cumulative 5,000-hour durability test, which proved reliability of the facility.

<IGCC System>

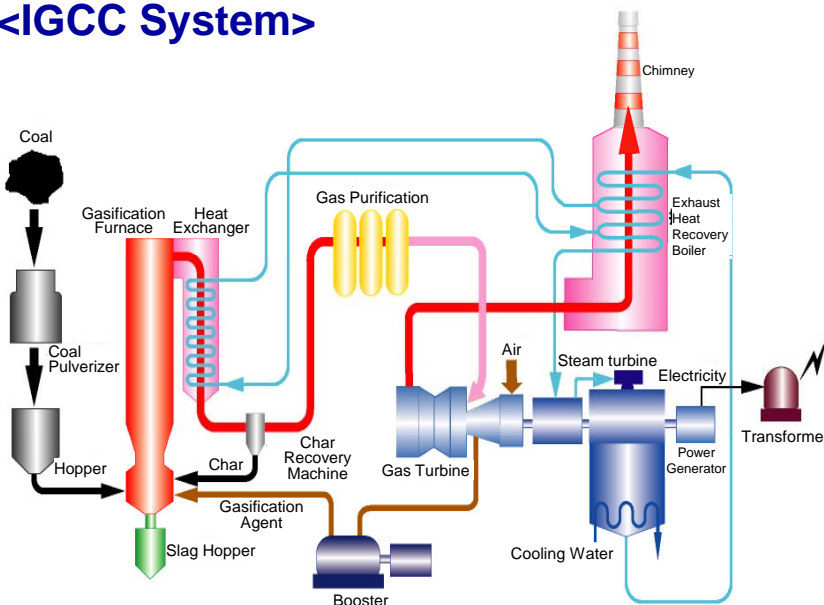

[Source] Clean Coal Power R&D Co., Ltd

<Overview of Experimental Facility>



<Specification of Facility>

Output	250MW class
Consumed coal	Approx. 1,700-ton/day
Target heat efficiency	42% (Net)
Gas turbine	1,200°C class
Gasification	Air blow, dry feed, two-stage entrained flow bed

Multi-purpose Coal Gasification Technology Development (EAGLE※) Project

※ Coal Energy Application for Gas, Liquid & Electricity



- NEDO and J-Power are jointly operating the project. A pilot test facility is located in the Wakamatsu laboratory site (Kitakyushu City, Fukuoka) of J-Power.
- The EAGLE technology will cover future application of IGFC (Integrated Coal Gasification Fuel Cell Combined Cycle), a next-generation technology, in addition to the application of IGCC.
- IGFC will be able to target 58% or more (Net thermal Efficiency).

<Overview of pilot test facility>



[Source] “2009 – 2010: Energy/
Environmental technology field”, NEDO

<Flow at test facility>

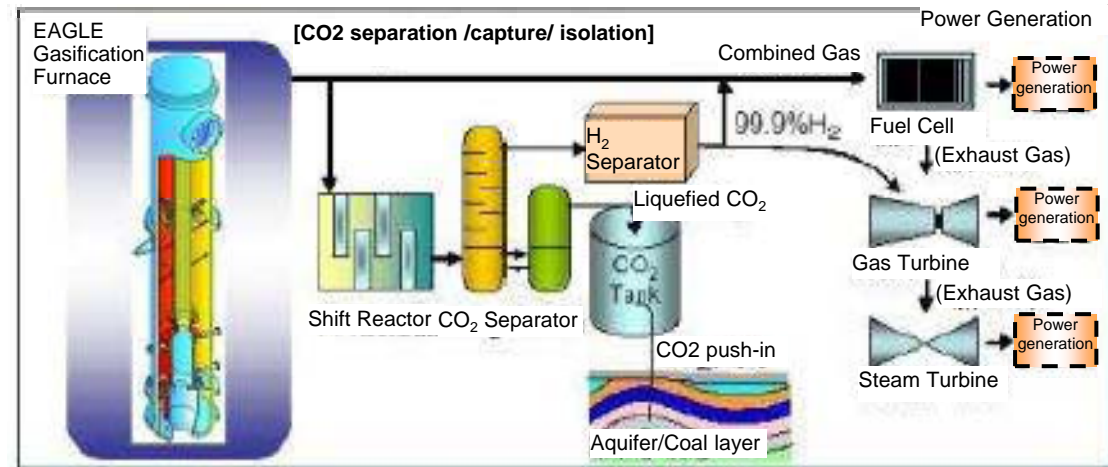

[Source] “Current condition of Japan coal policy (June 2009),” Agency for Natural Resources and Energy

<Major specification of pilot test facility>

GT output	8MW class
Consumed coal	Approx. 150 - ton/day
Gasification	Oxygen blown, 1 - chamber 2 - stage slewing entrained flow bed

- A-USC: Technology to improve thermal efficiency by making steam temperature and steam pressure much higher than USC.
 - Target of thermal efficiency of A-USC (700 °C class): 46 – 48% (HHV)
 - Technical challenge for practical application: Development of new heat-resistant material for boilers and steam turbines, which is tolerable against 700 °C or higher steam condition.

<System diagram of USC and A-USC steam power generation>

USC Steam Power Generation

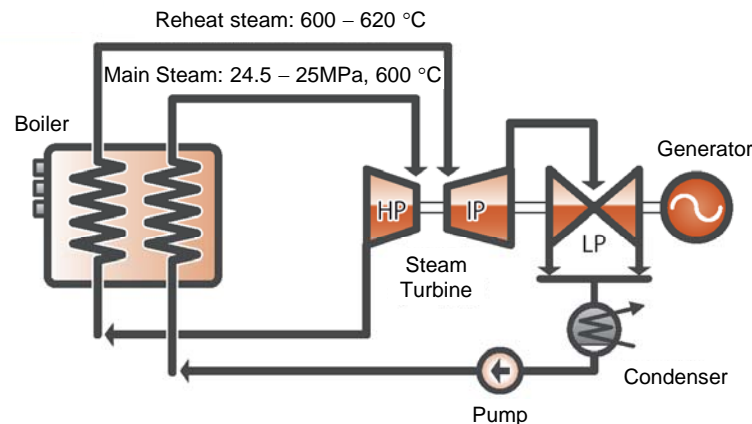

A-USC Steam Power Generation

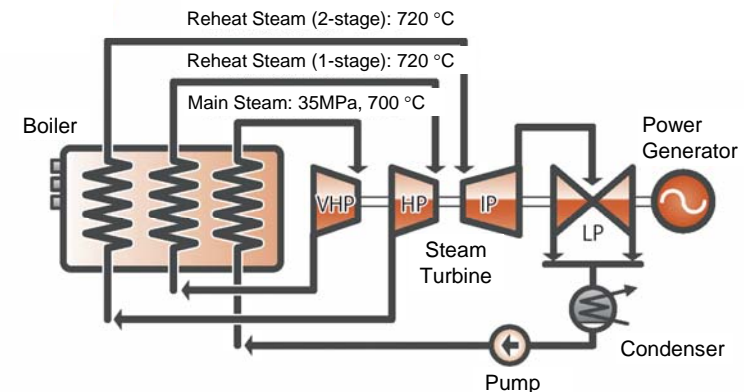

VHP: Very high pressure turbine/HP: High pressure turbine
IP: Intermediate pressure turbine/LP: Low pressure turbine

Net thermal efficiency : Approx. 42% (HHV)

Net thermal efficiency : Approx. 46~48% (HHV)

The electric power companies are aggressively deploying multi-fuel combustion with woody biomass in order to reduce CO₂ emission.

<Current status and plans of multi-fuel combustion with woody biomass conducted by domestic electric power companies (major sites only)>

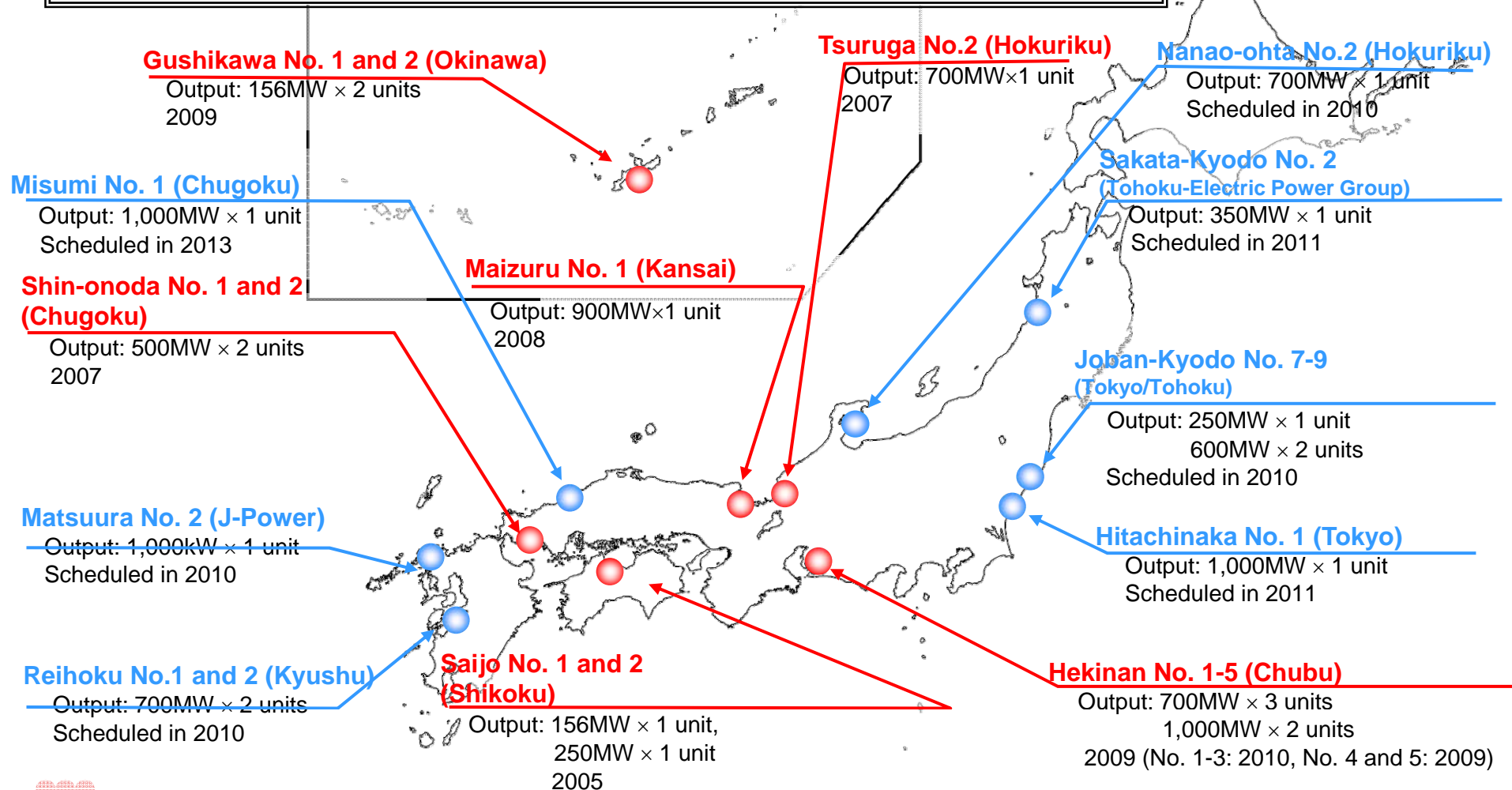

- Japan CCS Co.,Ltd., established by eleven electric power companies and companies in other industries, is operating governmental projects such as FS of CO₂ capture and research of proper sites for CO₂ storage.
- Since CCS has many problems to be solved and is still a developing technology, the Japanese government should take a leading part in basic research and verification tests related to the capture and storage technology.

<CCS>

- Technology to separate and capture CO₂ emitted from power plants, oil refineries, and other factories, and block it under the soil, deeper than 1,000 m or more
- Estimated CO₂ capture and storage potential with CCS: Approx. two trillion tons worldwide / Approx. 150 billion tons in Japan

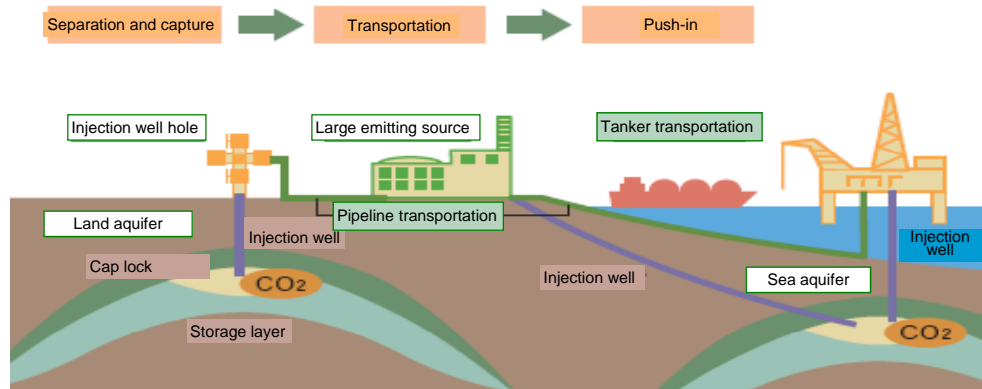

<Feasibility study (*) points >

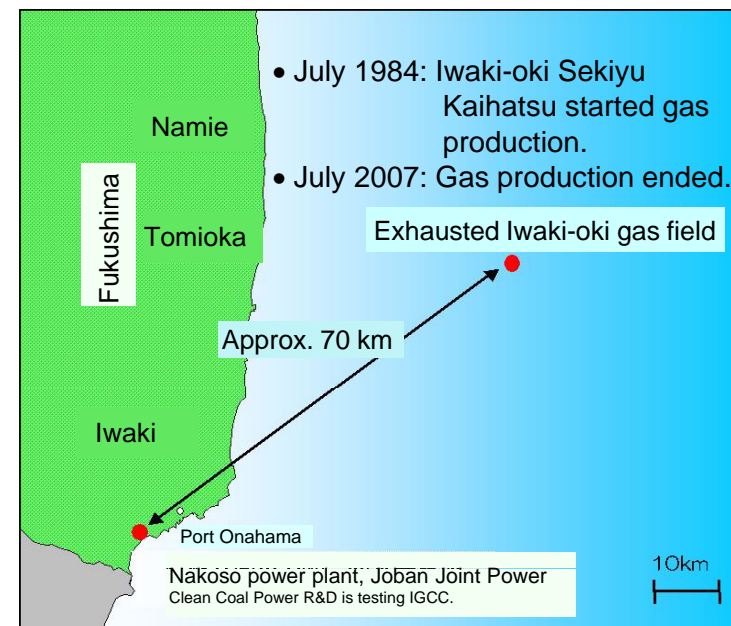

- In the feasibility study currently being conducted in Iwaki Sea of Fukushima(*), the total system from power generation to CO₂ storage is discussed (absorption system, heat mass balance, CO₂ capture quantity and so on.) (*) Project entrusted by NEDO

I. Current Situation and Prospects of the Use of
Coal-fired Power in the Electric Power Industry

II. Approaches to Advanced Use of Coal-fired Power

**III. International Cooperation through Coal-fired
Power Technologies**

- APP started in July 2005, with the goal of promotion of regional cooperation related to development, diffusion, and transfer of clean and effective technology, in order to take action in energy security, environment pollution, and climate change problems.
- At the initiative of the US, seven countries such as Australia, Korea, China, India, Japan, and Canada joined the activities.
- Compared with the CO₂ emission covering rate defined in Kyoto Protocol (about 28%), **the covering rate of APP is higher (about 55%), and its effectiveness is expected.**

8-field activities

<Electric power field>

- (1) Power generation and power transmission
(Preservation and recovery of thermal efficiency)
- (2) Cleaner fossil energy
(coal-fired power generation such as IGCC, CCS, Advanced ultra super critical pressure)
- (3) Renewable energy and distributed power generation
(Regional electrification)

<Other 5 fields by industry>

- (4) Aluminum, (5) Steel, (6) Cement,
- (7) Building and appliances, and
- (8) Coal Mining

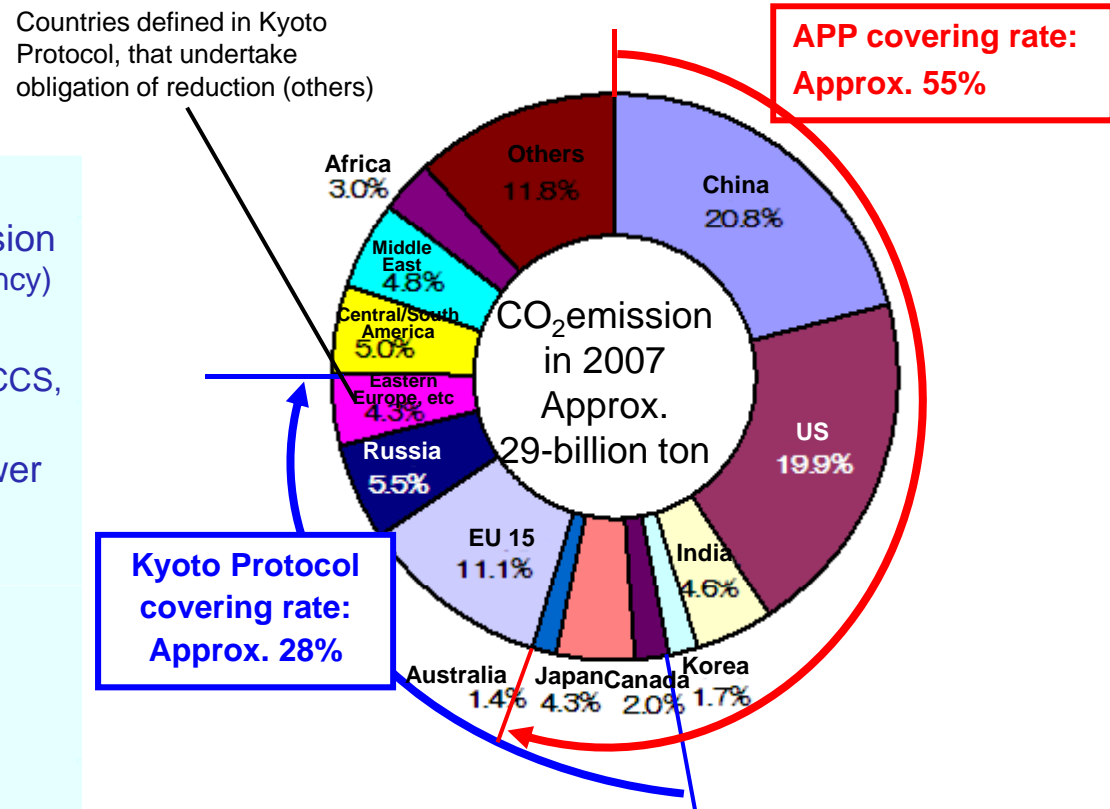

[Source] IEA CO₂ EMISSIONS FROM FUEL COMBUSTION 2009 EDITION

- For "power generation and transmission taskforce," engineers of various countries visit existing coal-fired thermal power plant each other and "Peer Review activity" for maintaining and improving the thermal efficiency is being carried out.
- The technological transfer is promoted through the communion between engineers and the best practice (good case example) of operation and maintenance management is shared utilizing the handbook and checklist.
- The Peer Review activity has been carried out five times and the suggestions on the improvement of plant operation is proposed and the recovery of efficiency is confirmed at various plants from aged plant to latest plant.

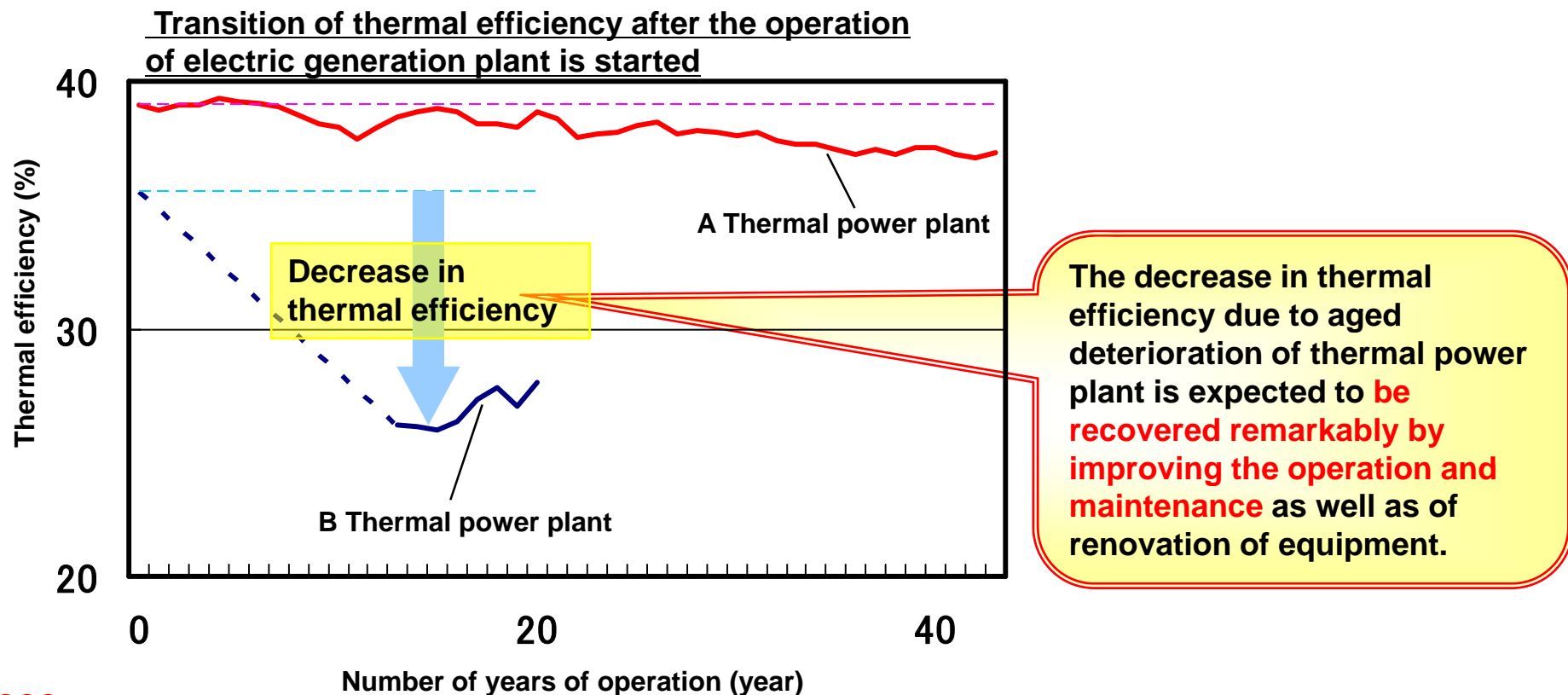

Peer Review Activity of APP at Existing Coal-fired Thermal Power Electric Generation Plant

- Peer Review (sharing of best practice through communication between engineers) for improving the thermal efficiency of existing coal-fired thermal power electric generation plant is being carried out as an activity of sectoral approach.
- It is carried out for diffusion and settlement of best practice of operation improvement with immediately achievable effects without the need for large scale modification.



Concrete accomplishment due to contribution of Japan



Creation of handbook summarizing the best practice of operation and maintenance

→ China is already utilizing it for the performance diagnosis of power plant

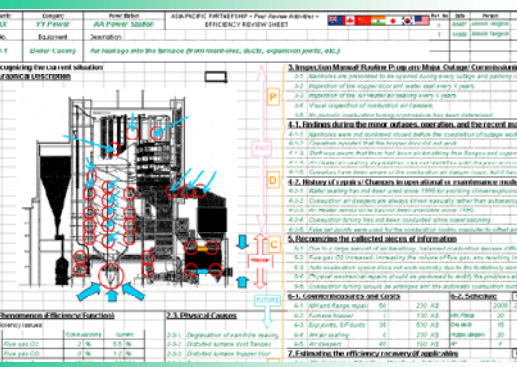

Creation of check list and review sheet for improving the thermal efficiency

→ Utilized for diagnosis of efficiency improvement for the power plant in India

Effect of CO₂ reduction if the best practice of operation improvement in countries that participate in APP and the thermal efficiency is improved (supposed to be 1%) by continuing the Peer Review is approximately 120 million t/year

- In Asian developing countries, the low-efficient and cheap Sub (subcritical pressure type) is the main stream and Chinese manufacturers have advantage.
- USC is BAT at the current moment. **We are aiming at the economic growth of Japan and realize the prevention of global warming** through the expansion of USC in Asia that Japan has technological advantage.

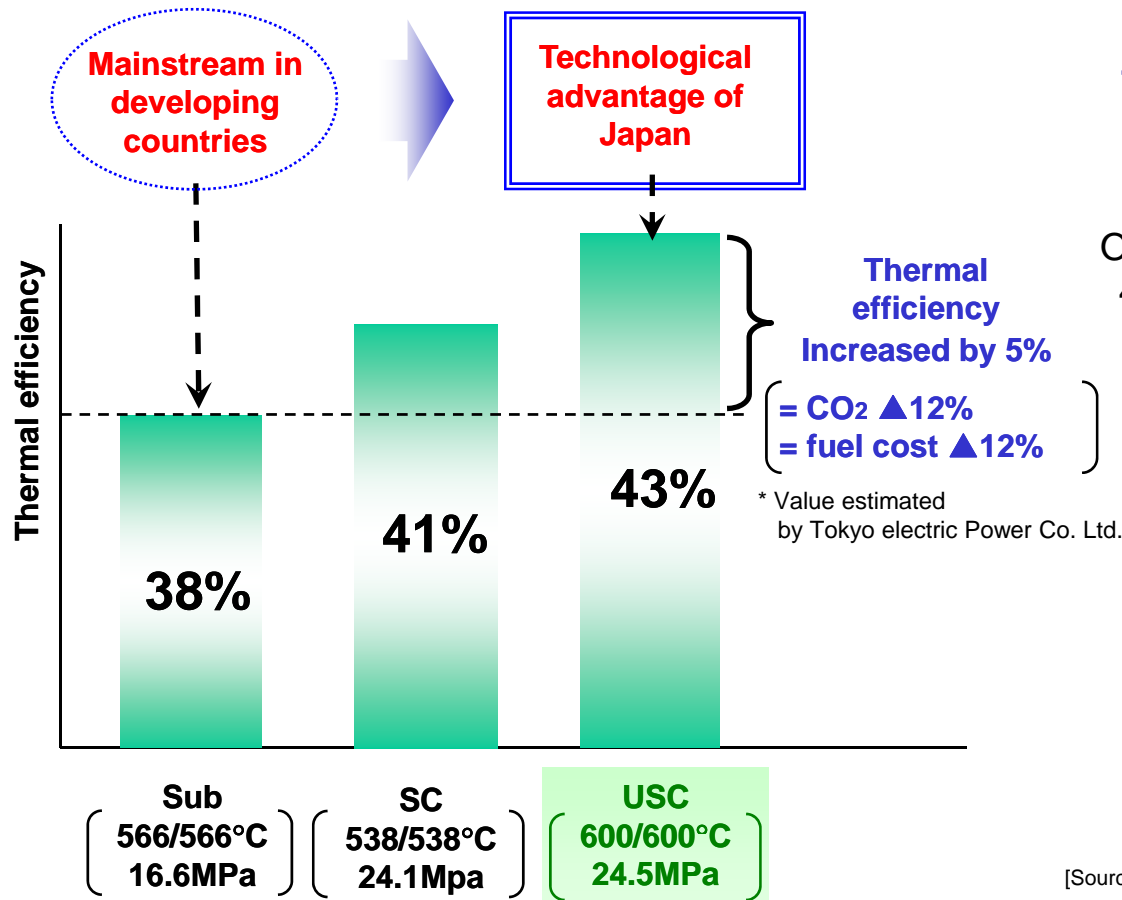

<International share of steam turbine>

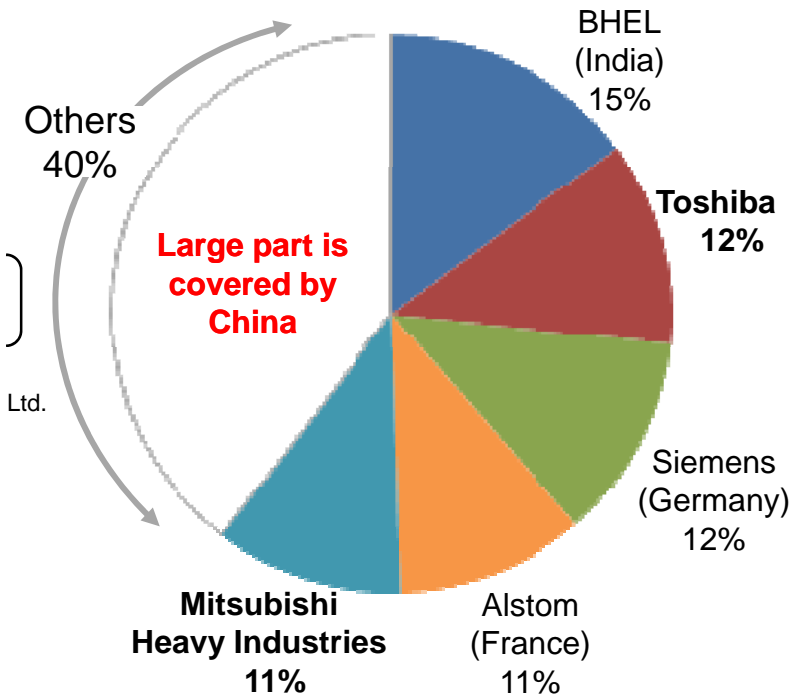

[Source] Industrial Structure Council, Ministry of Economy, Trade and Industry Document of 2nd Industrial competitive power session (26 March)

Scheme of Introduction of High-efficiency Coal-fired Thermal Power Plants by Public and Private Cooperation

- For the international expansion of USC that is superior in environmental property, but the construction cost is higher than that of existing type, the construction of financial scheme for complementing the difference is necessary.
- For the system of carbon credit between two countries that has been propounded, the concept is reflected to "New Growth Strategy" and "Industrial Structure Vision" that were formulated recently. For accelerating the international expansion of low-carbon infrastructure technology, the construction and the application of more than one schemes shown below will be requested.
 - Reduction of fuel cost upon the improvement of thermal efficiency
 - Wide application of public financial support such as yen credit granting
 - Utilization of carbon credit between two countries

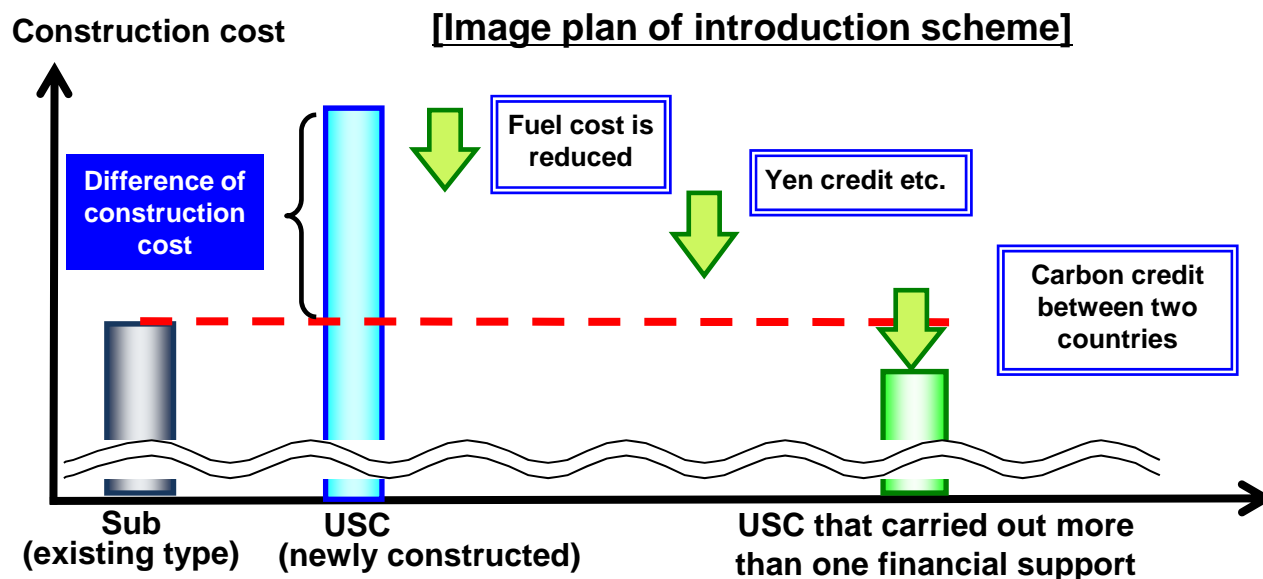

<Issues of carbon credit between two countries to be considered>

- (1) Early conclusion of agreement between governments related to distribution of emission reduction
- (2) Early construction of international framework that allows the carbon credit between two countries

[Reference] International Tendency of Technological Development of Zero-emission Coal-fired Power Generation

- The activities for the technological development of zero-emission coal-fired thermal power become activated all around the world.

<Japan: Cool Gen project>

- The experimental study project aiming at the realization of "zero-emission coal-fired thermal power electric power generation" combining IGCC, IGFC, and CCS is being promoted based on the technological development roadmap decided in "action plan for creating the low-carbon society"

US: Re-re- construction Future Gen project>

- 275MW IGCC+CCS plant on a commercial scale is constructed in Mattoon, Illinois. Approximately 90% of CO₂ is recovered (1 million t/y scale).
- DOE financed: 1.073 billion dollars

<China: Green Gen project>

- Project for carrying out the demonstration of coal gasification, hydrogen production, and CO₂ accumulation system.
- 1st period: 250MW, 2nd period: 400MW
- Currently, 250MWIGCC plant is being constructed in Tianjin aiming at the completion by 2011.
- Total amount of business is 1 billion dollars. The main body, Green Gen Co. is established by joint investment of five large electric power generation companies in China and National Development Group Corporation.

<Australia: Zero Gen project>

- 65 to 90% of CO₂ emitted from 530MW IGCC is planned to be recovered. 2 hundred thousand t/y is accumulated.
- Queensland state government leads the promotion of the project.
- The construction will be started in 2011. The operation is planned to be started in 2015.
- Total amount of business is 4.3 billion Australian dollars.

[Reference] Measures for Prevention of Air Pollution

- The coal-fired thermal power in Japan is equipped with "three sets against air pollution," flue-gas desulfurization equipment (SOx removal), flue-gas denitration equipment (NOx removal), electrostatic precipitator (dust removal) and the dust can be removed in high efficiency.
- Sox / NOx emission factor (average of fire power) in Japan is extremely lower than that of other countries.

<International comparison of SOx and NOx emission factor>

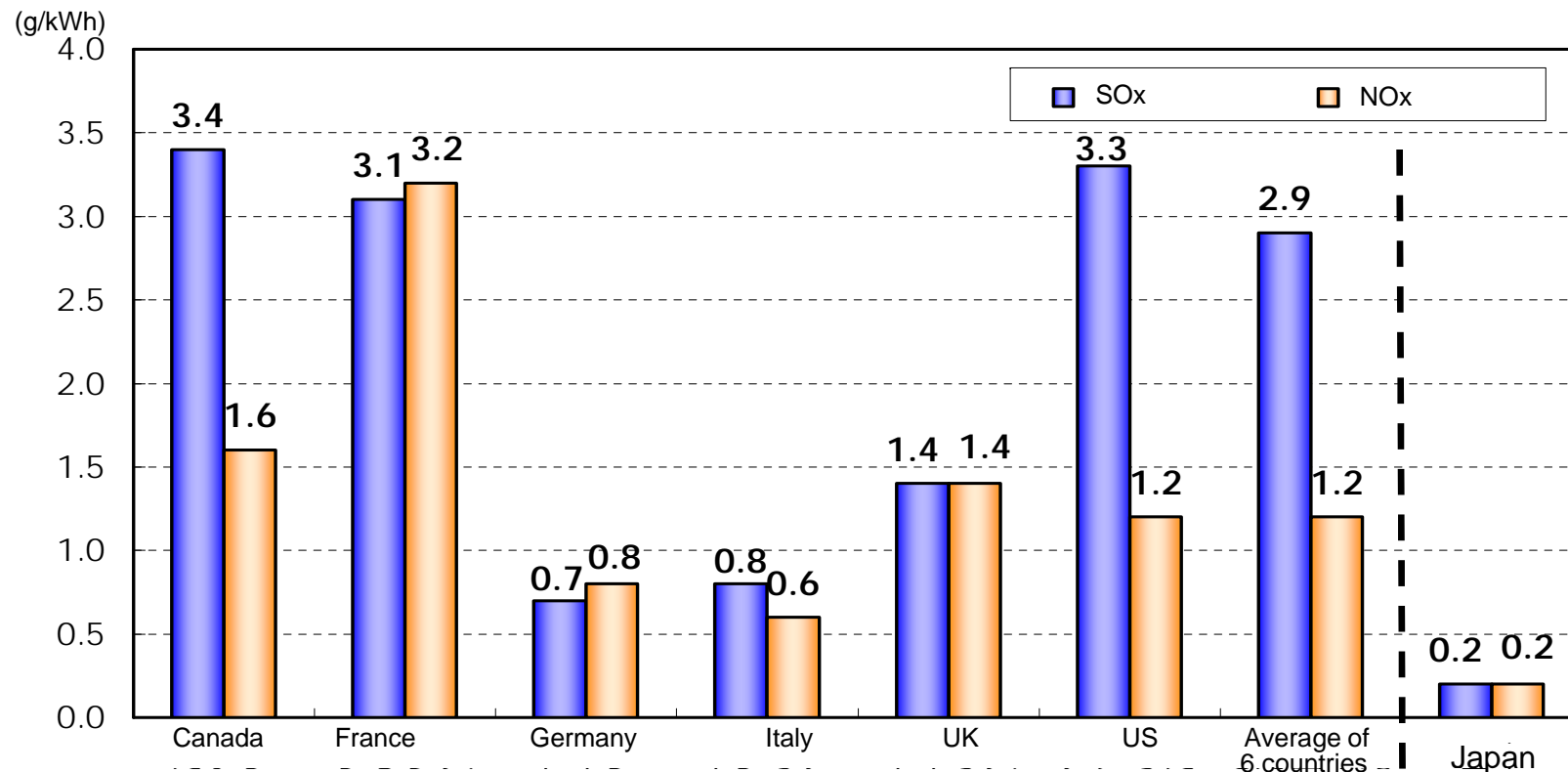

[Source] Estimated from OECD "OECD ENVIRONMENTAL DATA COMPENDIUM 2006/2007" and IEA "ENERGY BALANCES OF OECD COUNTRIES 2008 EDITION" by Tokyo Electric Power Co., Ltd.

[Reference] Measures Against NOx

- The ammonia is injected in the exhaust gas that contain NOx from boiler by flue-gas denitration equipment (ammonia selective catalytic reduction process) and the chemical reaction is promoted by the action of catalyser and NOx is resolved and decomposed to N₂ and H₂O (Tokyo Electric Power introduces it in Hitachinaka thermal power plant, Hirono thermal power plant, Chiba thermal power plant, and Yokohama thermal power plant etc.) .

[Flue-gas denitration equipment]



[Source] Tokyo Electric Power HP

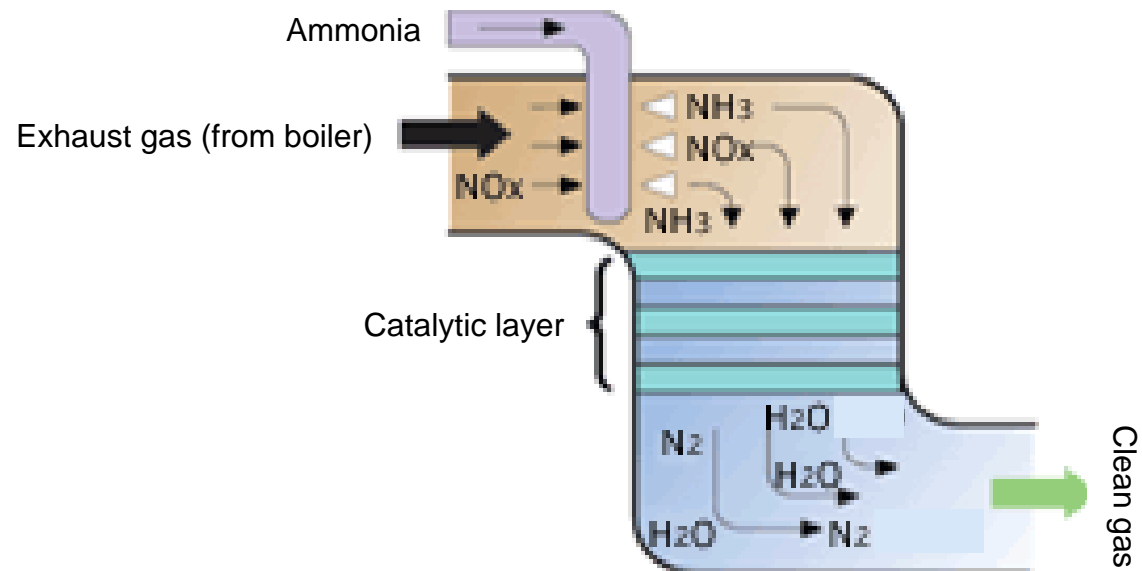

[Reference] Measures Against Dust

- System for collecting the dust by receiving the electric power to the direction of dust-collecting pole when the electric-charged dust passes through the electrode that discharges electricity in high voltage (Tokyo Electric Power installs the high-end electric dust collector for all thermal power plants excluding the gas dedicated combustion thermal power plants that do not discharge the dust.).

[Electric dust collector]

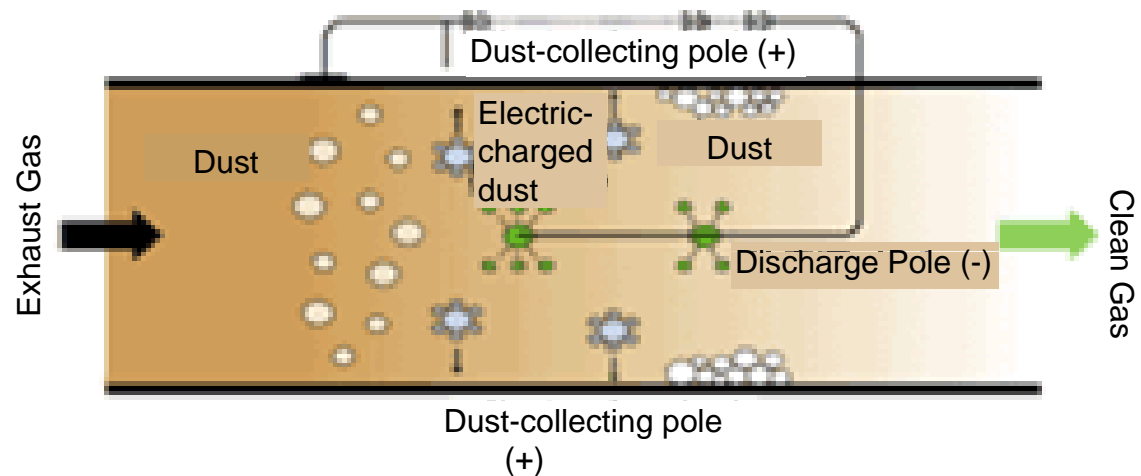
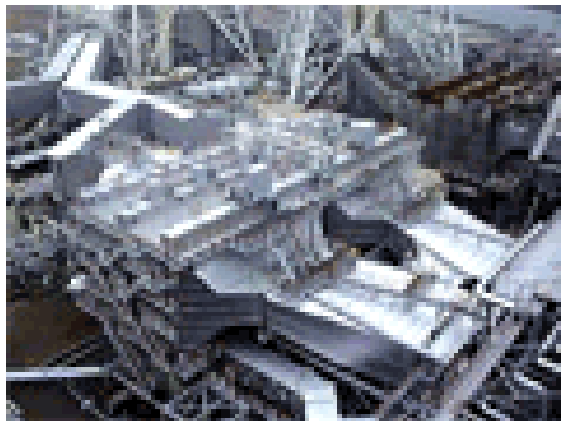

[Source] Tokyo Electric Power HP

[Reference] International Expansion of Package Type Infrastructure for Industrial Structure Vision

- The international expansion of package type infrastructure in "Asian economic strategy" in government's "new growth strategy" are described in "Industrial Structure Vision (announced on June 3)" of Ministry of Economy, Trade and Industry
- The "industrial structure vision" is parallelly discussed and summarized by Ministry of Economy, Trade and Industry for objectifying the policy for the accomplishment of "basic policy of new growth strategy (cabinet decision at the end of previous December)"

● Overall strategy

- (1) Strengthen international competitiveness of infrastructure related industries (form consortiums, etc.)
- (2) Strengthen financial assistance
(Restart JICA overseas loan soon, strengthen functions of JBIC & NEXI, support investment in infrastructure funds)
- (3) Cooperation starting from the planning stage
(Delhi Mumbai industrial corridor, etc.)
- (4) Packaged assistance, top level diplomacy
(Economic cooperation, financial assistance, education, technical cooperation, human resource development etc.) / (progress in top level diplomacy)
- (5) Manage international rules for promoting overseas expansion
- (6) Strengthen of government's promotion organization.
Build organization.
 - 1) Strengthen METI's initiatives
 - 2) Build all-japan organization

● Main Sectors

In each sector, arrange goals & action plan (support other countries in making master plans, form consortiums, human resources development, etc.)

- (1) Water
- (2) Coal-fired power & coal gasification plants
- (3) Electricity transmission
- (4) Nuclear power
- (5) Railways
- (6) Recycling
- (7) Space industry
- (8) Smart grid & smart community
- (9) Renewable energy
- (10) Information communications
- (11) Urban development & industrial parks

[Source] Ministry of Economy, Trade and Industry industrial structure vision 2010 (Industrial Structure Council, industrial competitive power session report)